

West Leechburg Borough
1015 Plazak St.
West Leechburg, PA 15656

No. _____

Date _____, 20____

Road or Street Name _____
(where work is to be done) County Tax Map No. _____

Application is hereby made by _____
(Name) (Phone No.)

of _____, Pennsylvania

for permission to construct, build or establish a driveway or access road intersecting with _____
at the following location: _____
(Address) (Road or Street Name)

The driveway or access road will be constructed, built or established with the following materials and in the following manner: _____

(Description of work to be done - attach drawing or plan)

DATA APPLICABLE TO THIS APPLICATION

1. Approximate date when work will be started _____
2. Approximate date when work will be completed _____
3. Will the proposed driveway or access road require the reconstruction, relocation, or alteration of drainage ditches, berms, or paved roads on the borough right of way? _____

The applicant agrees that all work shall be done in full compliance with Ordinance No. 296 of 2009 and its amendments of the Borough of West Leechburg and the laws of the Commonwealth of Pennsylvania, and that the applicant shall well and truly save, defend, and keep harmless the Borough of West Leechburg and its agents from and indemnify them against all actions, suits, demands, payments, costs and charges for or by reason of proposed work and all damages to persons or property resulting in any manner therefrom, or occurring in the prosecution of the work connected therewith, or from any other matter, cause or thing relating thereto.

Property owner is responsible for any drainage changes or increase in runoff.

Under and subject to all the conditions, restrictions, and regulations prescribed by the Borough and on the general provision and specification a true copy whereof is attached and made a part hereof, with the same force and effect as if written or printed herein and under and subject to special conditions, restrictions and regulations hereinafter set forth. Permittee shall be

responsible for providing visibility for traffic safety at point of connection to Borough right-of-way.

The applicant(s) is (are) an individual(s), partnership, corporation (other _____)
(describe)

Contractor's Name: _____

Address: _____

Phone No.: _____

applicant's signature(s)

DRIVEWAY PERMIT FEES

Any driveway permit that falls under the no harm provisions of the Stormwater Management Ordinance or any other borough ordinance applicable to the issuance of a driveway permit requires a fee of \$120.00. Any driveway permit where the no harm provisions of the Stormwater Management Ordinance or any other borough ordinance applicable to the issuance of a driveway permit are not applicable and require review by West Leechburg Borough including but not limited to its agents, employees, and engineer shall require a fee of all internal and external costs incurred in relation to any reviews, consideration, and inspection of plans submitted to the Borough with any fees and costs being charged to the applicant or the individual entity who submitted the plan for review. Internal costs shall be a reasonable fee for any applicable administrative costs. External fees shall be billed at a rate no more than the actual costs charges by profession consultant(s).

FOR BOROUGH USE ONLY

CONDITIONS

Construct driveway in accordance with the requirements of type _____ on attached instruction sheet.

Is a pipe required? _____ Sight distance is _____ adequate _____ inadequate

SPECIAL CONDITIONS

*PERMIT IS VALID ONLY AS LONG AS ALL REQUIRED CONDITIONS ARE MET

DATE APPLICATION RECEIVED _____

FEE RECEIVED \$ _____

PRELIMINARY APPROVAL DATE _____

FINAL APPROVAL DATE _____

PERMIT ISSUED BY _____

Borough Secretary or other Authorized Agent

APPLICANT TO CONTACT BOROUGH OFFICE FOR FINAL INSPECTION ONCE CONSTRUCTION IS COMPLETED

**WEST LEECHBURG BOROUGH
DRIVEWAY PERMIT INSTRUCTION SHEET**

NAME OF APPLICANT: _____ APPLICATION NO. _____

TAX MAP REFERENCE NUMBER: _____ INSPECTION DATE _____

ROAD OR STREET NAME: _____

IMPORTANT PROPOSED DRIVEWAY SITE MUST MEET THE INDICATED CONDITIONS BEFORE DRIVEWAY PERMIT CAN BE ISSUED - PREPARE SITE AS INDICATED BELOW

I. DRIVEWAY TYPE (FINISHED DRIVEWAY MUST CONFORM TO THE CONDITION INDICATED)

___ A) DRIVEWAY SLOPES TOWARD ROAD (ROADWAY WITHOUT CURBING)

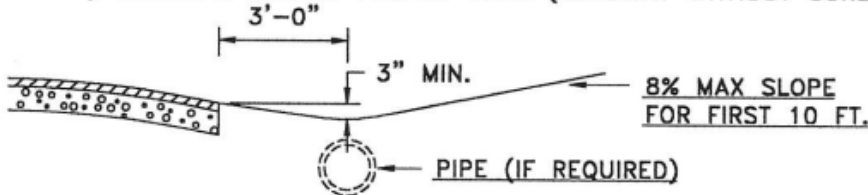

___ B1) DRIVEWAY ON ROAD WITH BITUMINOUS WEDGE CURBING



___ B2) DRIVEWAY ON ROAD WITH CONCRETE CURBING (DEPRESS CURB)



___ C) DRIVEWAY IS LEVEL OR SLOPES AWAY FROM ROAD (ROADWAY WITHOUT CURBING)

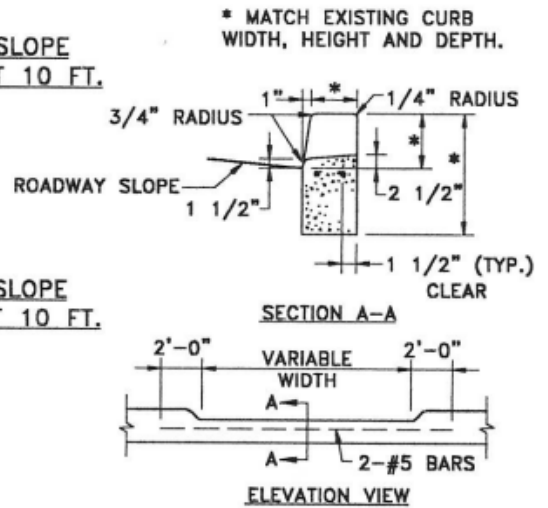
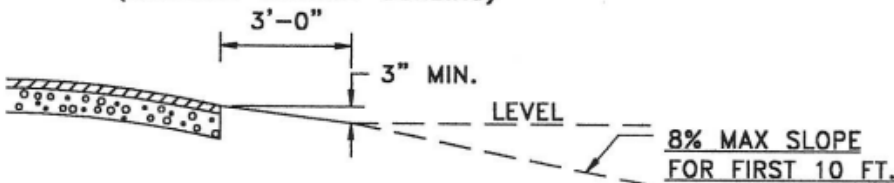

DEPRESSED CURB DETAILS
PROVIDE MATERIALS AND CONSTRUCTION MEETING PUBLICATION 408.

II. IS A PIPE REQUIRED UNDER THE DRIVEWAY FOR STORM DRAINAGE? YES NO

IF YES PIPE SHALL BE LOCATED 3 FEET FROM EDGE OF ROAD OR AS FOLLOWS:

_____ (MINIMUM PIPE SIZE 15 INCH DIAMETER)

III. SAFE SIGHT DISTANCE (NO PERMIT WILL BE ISSUED WITH INADEQUATE SIGHT DISTANCE.)

REQUIRED SIGHT DISTANCE IN FEET

<u>SPEED LIMIT</u>	<u>LEFT</u>	<u>RIGHT</u>
25 MPH	250	195
35 MPH	440	350

ACTUAL SIGHT DISTANCE

<u>SPEED LIMIT</u>	<u>LEFT</u>	<u>RIGHT</u>	<u>DATE</u>
____ MPH	____	____	____
____ MPH	____	____	____

SIGHT DISTANCE HAS BEEN DETERMINED TO BE: ____ ADEQUATE ____ INADEQUATE
 ____ SIGHT DISTANCE IS BLOCKED BY: TREES, SIGNS, BUILDINGS, EARTH, _____
 (SIGHT DISTANCE IS MEASURED FROM A VEHICLE 10 FEET BACK OF THE PAVEMENT)

WHEN ALL CONDITIONS HAVE BEEN MET, CONTACT BOROUGH OFFICE FOR FINAL INSPECTION

SPECIAL CONDITIONS

NOTES:

BEFORE YOU DIG ANYWHERE IN PENNSYLVANIA, CALL 1(800) 242-1776. NON-MEMBERS MUST BE CONTACTED DIRECTLY. PA. ACT 172 (1986) REQUIRES (3) WORKING DAYS TO UTILITIES BEFORE YOU EXCAVATE, DRILL, BLAST, OR DEMOLISH.

PROPERTY OWNER RESPONSIBLE FOR ANY DRAINAGE CHANGE OR INCREASE IN RUNOFF.

